

MOVE cabinets

Design by Gediminas Juška | Lithuania

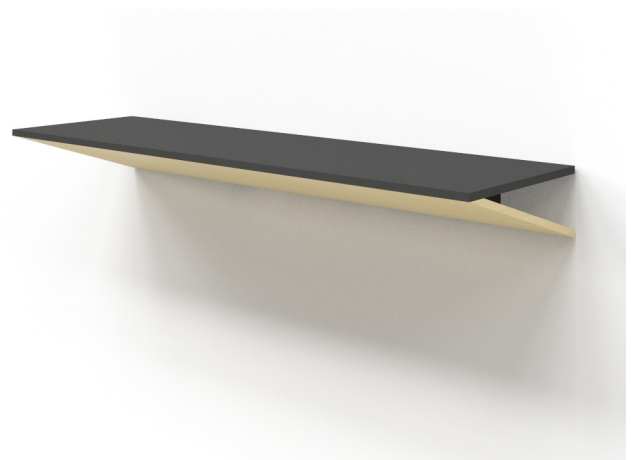

Wardrobes and cabinets with 4 shelves



Wall shelves

FEATURES

- Left or right option;
- Free standing;
- High quality wood veneer with HPL Fenix;
- Adjustable shelf height.

TECHNICAL INFORMATION

Carcass

- 18 mm chipboard covered in wood veneer;
- Milled side panel for convenient door opening;
- Natural wood / 0,5 mm veneer lacquered edging.

Shelves

- 18 mm MFC (melamine) with 1mm ABS edging, coloured in black by default;
- Shelf load capacity: 15 kg.

Doors

- 18 mm plywood covered in HPL with lacquered plywood edging;
- 155° opening angle with soft closing system.

Base

- Black plastic height levelling feet, H=17 mm (+10 mm).

FEATURES

- High quality wood veneer with HPL Fenix.

TECHNICAL INFORMATION

Carcass

- 12 mm chipboard covered in HPL Fenix with 1 mm ABS edging;
- 12 mm plywood covered in wood veneer;
- 18 mm MFC (melamine) with 1 mm ABS edging, coloured in black by default;
- 25 mm MDF;
- Load capacity: 10 kg.

MATERIALS

- HPL Fenix: H16 (black), H17 (grey);
- Veneer: V1 (ash), A (oak), R (walnut).

GUARANTEE

- 5 years

RANGE

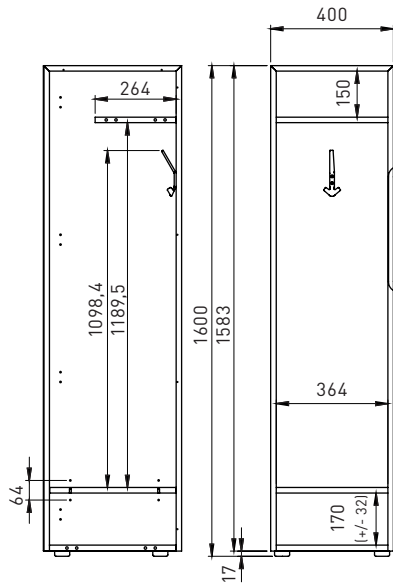

Wardrobe with hook

L/H, R/H

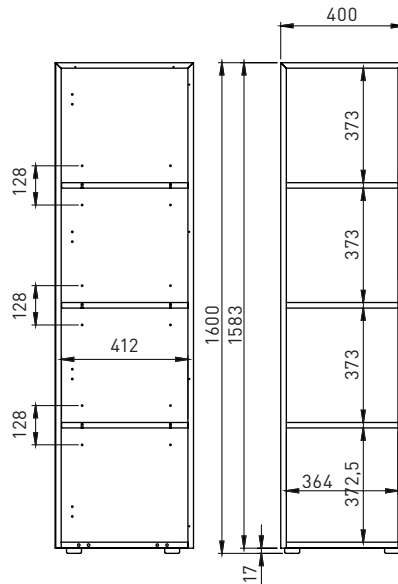

Cabinet with 4 fixed shelves

L/H, R/H

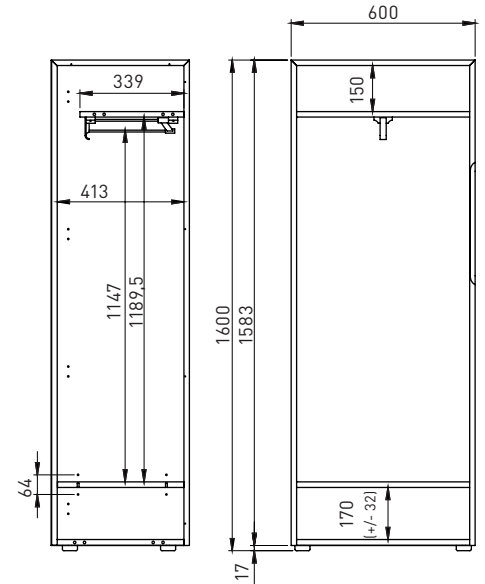

Wardrobe with pull out rail

L/H, R/H

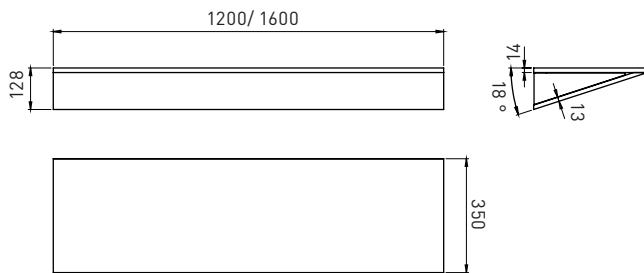

Wall shelves